



# Classic™

Fuel-Fired Vertical  
Tubeless Steam Boilers

4 – 60 BHP



▶ Feedwater/Condensate Return  
Systems & Blow-down Tanks  
(Horizontal & Vertical)

# FULTON FUEL-FIRED VERTICAL TUBELESS BOILERS

## FULTON: AN INDUSTRY LEADER SINCE 1949

Since Fulton's invention of the vertical tubeless boiler in 1949, Fulton has been the leading U.S. manufacturer of this type of boiler. For over 70 years, more than 100,000 boilers have been produced and installed world-wide.

Every Fulton boiler is built and stamped to ASME Code and registered with the National Board of Boiler and Pressure Vessel Inspectors. Fulton boilers are UL listed boilers – not just the burner or electrical components – the entire boiler and they are CSA approved.

*A vertical tubeless boiler is a relatively simple design, offering years of trouble-free operation*

Many Fulton boilers over 30 years of age are still in operation today. There are no tubes or coils to rust or burn out periodically, therefore, no retubing costs, no downtime. No downtime means increased productivity.



*Complete control panel box houses all necessary operating components*

The 7800 Series Microprocessor based controls are standard. A trouble shooting display module is optional. Fulton's commitment to continuous product improvement is reflected in the efficiency, quality, and ruggedness of these superior standard fuel-fired boilers.

*All Fulton Boilers can be ordered with a polished stainless steel jacket*

Ask your Fulton distributor how little extra it can cost for stainless.



*Unique features begin with simplicity*

The furnace (pressure vessel) is, simply stated, a "pipe within a pipe". The top mounted Fulton power burner sends a spinning cyclonic flame into and down the center furnace chamber.

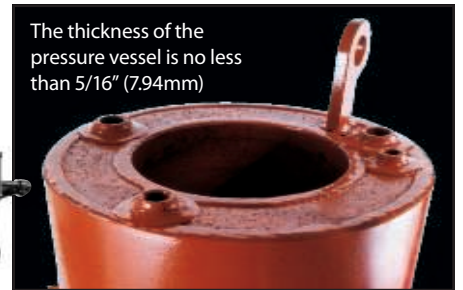

The thickness of the pressure vessel is no less than 5/16" (7.94mm)

With fuel to steam efficiencies in the low 80's. The Classic has time proven top mounted matched burner with the downward cyclonic flame.

It features the Fulton engineered Flue Gas Enhancing System (FGE). A highly efficient two pass design, the Fulton FGE system works by using a massive heat transfer surface with high velocity flue gasses traveling over a cylindrical grid of heat convection fins.

Through controlled velocities these fins transmit additional heat evenly to the outer side of the water vessel, creating high efficiencies with lower stack temperatures.

*Dramatic stack temp. reductions*

With the Fulton Classic stack temperatures can be from 100-150°F below standard two pass designs and have cut previous fuel bills in half!

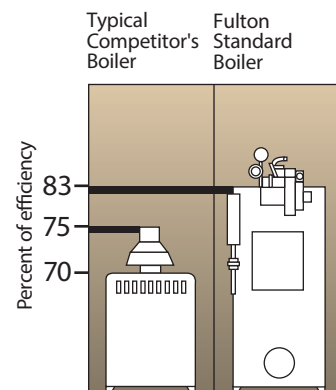

# A LOOK INSIDE FULTON'S VERTICAL TUBELESS BOILER

The Fulton standard top fired power burner

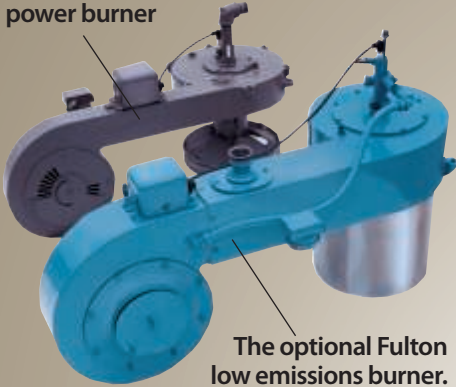

The optional Fulton low emissions burner.  
( $< 20\text{PPM NO}_x$  and  $< 60\text{PPM CO}$ )

*Fulton fuel-fired boilers can be ordered with combination fuel capabilities or be converted to combination fuels simply and economically.*

All fuel-fired boilers feature the Fulton designed and manufactured top mounted down fired forced draft burner.

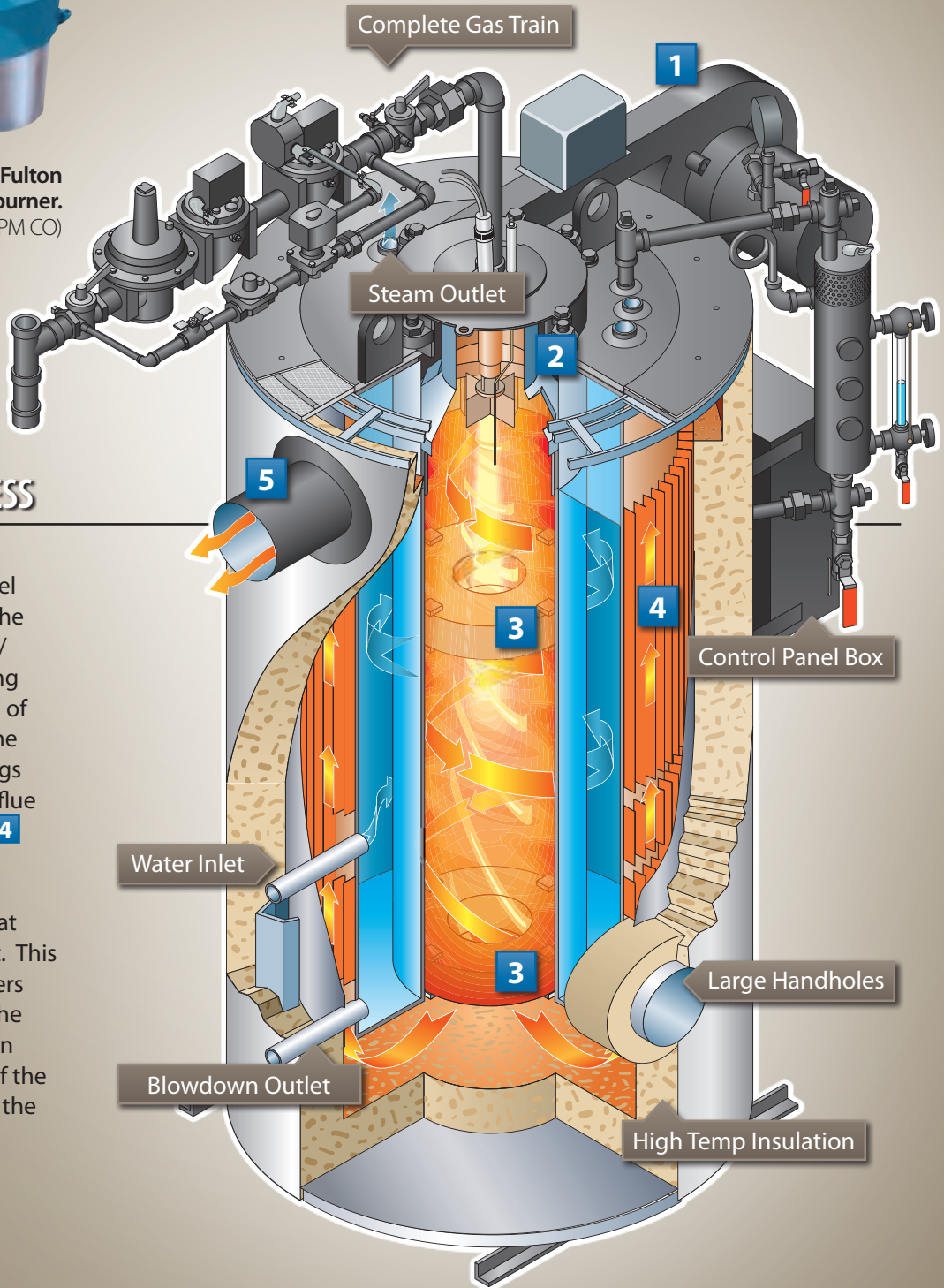

## THE COMBUSTION PROCESS

**1** Air is drawn into the power burner where it is mixed with fuel for optimum combustion. **2** The ignition assembly ignites the air/fuel mixture and sends a spinning cyclonic flame down the length of the furnace chamber, forming the first pass. **3** Flame retainer rings increase occupancy time of the flue gases increasing heat transfer. **4** The flue gases are turned at the base of the chamber and return over the heat convection fins that surround the entire water jacket. This is the second pass, which transfers additional heat to the water in the vessel. **5** The flue gases are then collected at the upper portion of the boiler and are expelled through the flue outlet.

# DIMENSIONS, WEIGHTS

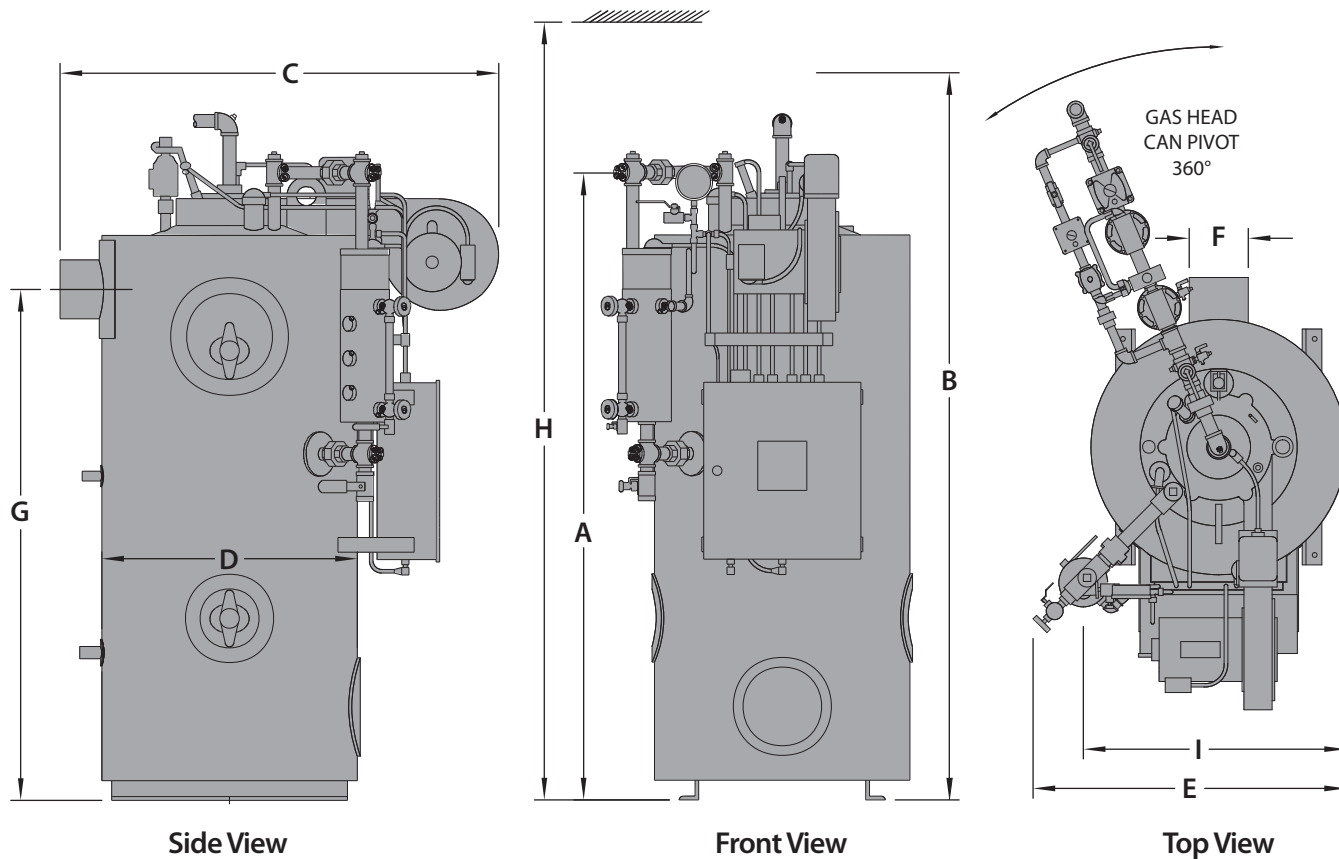

## CLASSIC MODELS FB-A/ICS

Classic Models FB-A/ICS		4	6	9.5	10	15	20	25	30	50	60
<b>Unit Size:</b>	HP	4	6	9.5	10	15	20	25	30	50	60
<b>Heights and Widths</b>											
<b>(A) Boiler Minimum Height</b>	IN	57	68	79	76	83	83	85	93	95	101
	MM	1447	1712	1986	1921	2096	2089	2140	2343	2397	2550
<b>(B) Boiler Height With Trim and Fuel Train</b>	IN	63	74	84	80	86	92	94	105	114	120
	MM	1601	1866	2118	2029	2181	2315	2365	2561	2886	3038
<b>(C) Overall Depth Stack</b>	IN	44	44	44	45	47	59.5	60	66.5	77	77
<b>to Burner Fan Housing</b>	MM	1118	1118	1118	1143	1194	1511	1524	1689	1956	1956
<b>(D) Boiler Diameter</b>	IN	26	26	26	28	30	39	39	46	55	55
	MM	660	660	660	711	762	991	991	1168	1397	1397
<b>(E) Overall Width</b>	IN	35.5	35.5	35.5	37	39	46.5	47	52.5	60	60
<b>with Water Column</b>	MM	902	902	902	940	991	1181	1194	1334	1524	1524
<b>(F) Flue Outlet Diameter</b>	IN	6	6	6	6	8	10	10	12	12	12
	MM	152	152	152	152	203	254	254	305	305	305
<b>(G) To Center of Flue Outlet</b>	IN	42	52	62	58	63	65	66	73.5	79	85
	MM	1070	1320	1575	1473	1600	1651	1676	1867	2007	2159
<b>Minimum Clearances</b>											
<b>(H) Clearance for Burner Removal *✱</b>	IN	72	82	92	86	92	96	98	106	114	124
	MM	1828	2083	2337	2184	2337	2438	2490	2692	2896	3150
<b>(I) Opening Required for Installation</b>	IN	26	26	26	28	30	39	39	46	55	55
<b>With Water Column Removed</b>	MM	660	660	660	711	762	991	991	1168	1397	1397
<b>Front of Boiler</b>	IN	36	36	36	36	36	36	36	36	36	36
	MM	915	915	915	915	915	915	915	915	915	915
<b>Sides &amp; Rear of Boiler</b>	IN	24	24	24	24	24	24	24	24	24	24
	MM	610	610	610	610	610	610	610	610	610	610
<b>Weights</b>											
<b>Approx. Shipping Weight</b>	LB	1500	1780	2050	2000	2400	3750	3690	5450	7860	8260
	KG	680	807	929	910	1088	1700	1673	2472	3565	3747

\* This dimension is 6" less for oil-fired units 6-50 HP and 12" less for oil-fired units 60 HP. ✱ Add 6" for low emissions burner removal.

# AND SPECIFICATIONS

Classic Models FB-A/ICS			4	6	9.5	10	15	20	25	30	50	60
<b>Unit Size:</b>	<b>HP</b>		4	6	9.5	10	15	20	25	30	50	60
Ratings* (Sea level to 3000 ft.)												
<b>Output</b>	<b>1,000 BTU/HR</b>		134	201	319	335	503	670	837	1,005	1,674	2009
	<b>1,000 KCAL/HR</b>		34	51	81	85	127	169	211	254	422	507
<b>Steam Output</b>	<b>LB/HR</b>		138	207	328	345	518	690	863	1,035	1,725	2,070
	<b>KG/HR</b>		63	94	149	157	235	313	392	470	785	939
Approximate Fuel Consumption at Rated Capacity+												
<b>Light Oil</b>	<b>GPH</b>		N/A	N/A	2.9	3.0	4.5	6.0	N/A	9	15.0	18.0
	<b>LPH</b>		N/A	N/A	11.0	11.4	17.0	22.7	N/A	34.1	56.8	68.1
<b>Propane Gas</b>	<b>FT3/HR</b>		67	97	154	161	242	323	419	484	837	1005
	<b>M3/HR</b>		1.9	2.7	4.4	4.6	6.9	9.1	11.9	13.7	23.7	28.5
<b>Natural Gas</b>	<b>FT3/HR</b>		168	242	384	404	605	807	1046	1210	2093	2511
	<b>M3/HR</b>		4.8	6.9	10.9	11.4	17.2	22.9	29.6	34.3	59.3	71.1
<b>Nat. Gas Boiler Connection Size</b>	<b>IN</b>		1	1	1	1	1	1.25	1.25	1.5	1.5**	2
	<b>MM</b>		25	25	25	25						
<b>Burner Motor HP</b>	<b>Gas 3450 RPM/60 CY</b>		.33	.33	.33	.33	.33	.33 gas	.75	.75 gas	1.5 gas	1.5 gas
	<b>Oil</b>				.33	.33	.33	.75	N/A	.75	2	2
Electric Power Requirements (in Amps)												
<b>Gas</b>	<b>120V, 60 CY, 1 Phase</b>		7.2	7.2	7.2	7.2	7.2	7.2 gas	13.8 gas	13.8	20	20
<b>Oil</b>			7.2	7.2	7.2	7.2	7.2	13.8 oil	13.8 oil	13.8 oil	24 oil	24 oil
<b>Gas</b>	<b>240V, 50/60 CY, 1 Phase</b>		3.6	3.6	3.6	3.6	3.6	3.6 gas	6.9 gas	6.9	10 gas	10 gas
<b>Oil</b>			3.6	3.6	7.2	7.2	7.2	6.9	6.9	6.9	12	12
<b>Gas</b>	<b>208V, 50/60 CY, 3 Phase</b>		2.4	2.4	2.4	2.4	2.4	2.4 gas	3.7 gas	3.7	6.9 gas	6.9 gas
<b>Oil</b>			2.4	2.4	2.4	2.4	2.4	3.5	3.7	3.7	7.8	7.8
<b>Gas</b>	<b>240V, 50/60 CY, 3 Phase</b>		2.2	2.2	2.2	2.2	2.2	2.2 gas	3.2 gas	3.2	6.0 gas	6.0 gas
<b>Oil</b>			2.2	2.2	2.2	2.2	2.2	3.2	3.2	3.2	6.8	6.8
<b>Gas</b>	<b>480V, 50/60 CY, 3 Phase</b>		1.1	1.1	1.1	1.1	1.1	1.1 gas	1.6 gas	1.6	3.0 gas	3.0 gas
<b>Oil</b>			1.1		1.1	1.1	1.1	1.6	1.6	1.6	3.4	3.4
Water Content												
	<b>GALLONS</b>		14	16	16	24	39	77	82	170	245	270
	<b>LITERS</b>		53	61	61	91	148	291	310	644	927	1022

\*Note: All piped connections are <3" are NPT, >3" ANSI 150 flange

+ Consumption based on Light Oil 140,000 BTU/G; Natural Gas 1010 BTU/ft<sup>3</sup>; Propane 2530 BTU/ft<sup>3</sup>.

\* All ratings from 0 PSIG and at 212°F. • ✱ Consult Factory • \*\* 2"/51mm IRI and CSA • N/A-Not Available

Specifications and Dimensions are approximate. We reserve the right to change specifications and/or dimensions without notice. Diagram for guidance purposes only. Comprehensive details of dimensions, connections, etc. for each model are given on product dimension data sheets available from Fulton.

## Boiler, Condensate Tank, and Blow-Down Separator

Condensate return tank should be vented and have a capacity sufficient to satisfy boiler consumption and maintain proper return tank temperature. Vent pipe should not be down-sized (may cause pressure build up in the condensate tank). Return pipes must not be insulated.

See Return System Instruction Manual.

Optional barometric damper is recommended for most installations.

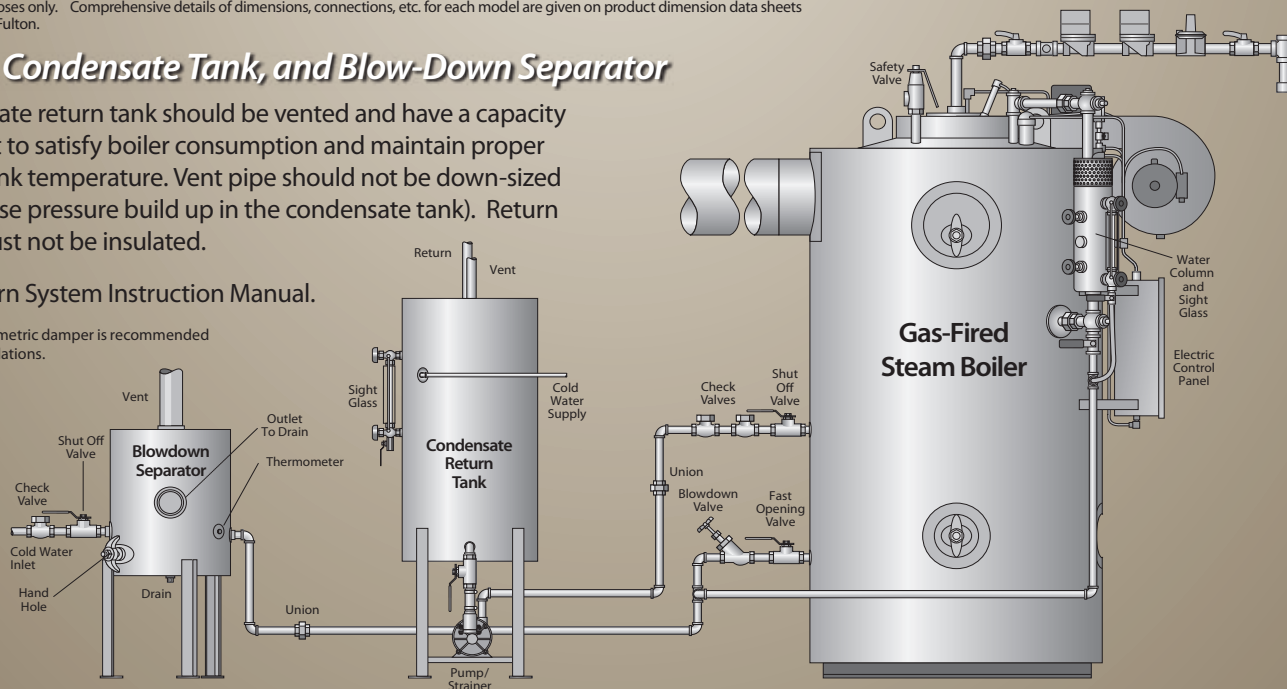

# HORIZONTAL FEEDWATER/CONDENSATE RETURN SYSTEMS

## FEATURES

Fulton condensate return systems are completely assembled with tank, stand, high pressure pump, motor, strainer, float valve, shut-off valve, gauge glass assembly, with overflow and drain openings.

- Heavy gauge properly sized tanks built for quick installation and removal or replacement
- Heavy duty feed water pump
- Rigid welded support frame



*Horizontal Condensate Return Systems Designed For Boilers From 22 HP to 200 HP*

Optional preheat kits are available.

Standard pump is good for 212°F maximum water temperature. Pumps for higher temperature water are available upon request.

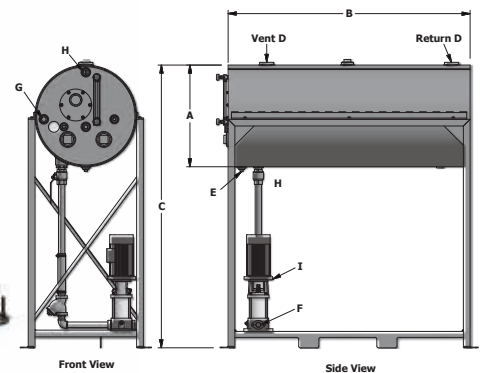

## SPECIFICATIONS & DIMENSIONS

	Model HT	30	60	100	200
For Boiler Size	HP	22-30	51-60	81-100	151-200
Full Capacity	GALLONS	46	94	147	220
	LITERS	174	356	556	833
Weight	LBS	195	465	650	1190
	KGS	89	211	295	540
<b>DIMENSIONS</b>					
(A) Tank Diameter	IN	18	24	30	30
	MM	457	610	762	762
(B) Tank Length	IN	42	48	48	72
	MM	1067	1219	1219	1829
(C) Overall Height	IN	45	52	80	80
	MM	1143	1321	2032	2032
<b>CONNECTIONS</b>					
(D) Vent/Return	IN	1.25	2	3	3
	MM	32	51	76	76
(E) Drain	IN	.50	1	1	1
	MM	13	25	25	25
(F) Pump Outlet	IN	1	1	1	1.25
	MM	25	25	25	32
(G) Cold Water Inlet	IN	.50	.75	.75	1
	MM	13	19	19	25
(H)* Overflow Opening	IN	1	1	1	1
	MM	25	25	25	25
(I) Pump HP	1 Ph. Motor	2	*	3	7.5
	(High Pres Blr)	3 Ph. Motor	2	5	3
(I) Pump HP	1 Ph. Motor	.33	1	.5	1
	(Low Pres Blr)	3 Ph. Motor	.33	1	.5

\* Overflow opening must be piped to drain. \* Consult Factory

Consult Factory for larger sized tanks.

# VERTICAL FEEDWATER/CONDENSATE RETURN SYSTEMS

## FEATURES

Both the horizontal and the vertical condensate return systems are available in heavy gauge "long lasting" steel only. Vertical tanks have all the same assembly components that the horizontal tanks do.

- Increased pump life under normal operation because of higher head pressure
- Vertical return systems can be ordered separately or skid-mounted and piped to your boiler
- Easily serviced from the top
- Complete float assembly can be removed without draining tank

\* Note for < 80°F Applications

*Vertical Condensate Return Systems Designed For Compact Space Saving Applications For Boilers From 1 HP up to 100 HP*

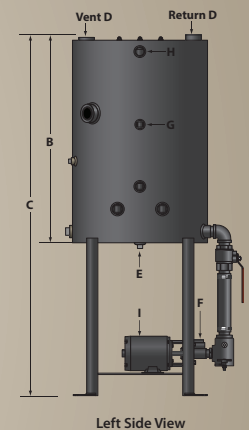
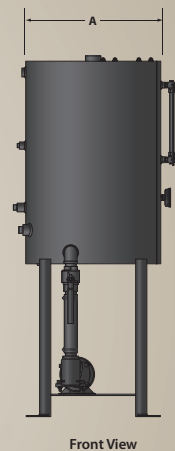

## SPECIFICATIONS & DIMENSIONS

Model VT		30			60		100	
For Boiler Size	HP	1 - 30			31 - 60		61 - 100	
Full Capacity	GALLONS	46			94		147	
	LITERS	174			356		556	
Weight	LBS	195			465		650	
	KGS	89			211		295	
<b>DIMENSIONS</b>								
(A) Tank Diameter	IN	18			24		30	
	MM	457			610		762	
(B) Tank Height	IN	42			48		48	
	MM	1067			1219		1219	
(C) Overall Height	IN	63			71		71	
	Floor-Top Of Tank	MM	1600			1803		1803
<b>CONNECTIONS</b>								
(D) Vent/Return	IN	1.25			2		2	
	MM	32			51		51	
(E) Drain	IN	.50			1		1	
	MM	13			25		25	
(F) Pump Outlet	IN	1			1		1	
	MM	25			25		25	
(G) Cold Water Inlet	IN	.50			.75		.75	
	MM	13			19		19	
(H)* Overflow Opening	IN	1			1		1	
	MM	25			25		25	
Boiler HP		1-12.5	13-21	22-30	31-50	51-60	61-80	81-100
(I) Pump HP	1 Ph. Motor	.5	.75	2	2	5	5	5
	(High Pres Blr)	3 Ph. Motor	.5	.75	2	2	5	5
(II) Pump HP	1 Ph. Motor	.25	.33	.33	.5	1	1	1
	(Low Pres Blr)	3 Ph. Motor	.25	.33	.33	.5	1	1

\* Overflow opening must be piped to drain.

# BLOW-DOWN TANKS

## FEATURES

Constructed with the finest quality materials, all compact Fulton Blow-Down Tanks meet or exceed ASME Code and include special features to insure safe boiler blow-down. Fulton Blow-Down Tanks also operate with minimum maintenance.

- Baffle plate absorbs steam flash and pressure
- Steam is expelled safely through vent
- Water and sludge pass through drain to sewer
- 3" x 4" handhole for cleaning and inspection
- Welded to ASME Pressure Vessel Code
- Fast, easy hook-up to boiler

Optional cooling kits available.

### *Fulton's full line of heat transfer products includes:*

- Fuel-fired vertical tubeless steam and hot water boilers
- Electric steam and hot water boilers
- Condensing and non-condensing commercial heating boilers
- Fuel-fired and electric thermal fluid heaters
- Customized sequencing and complete system control solutions

## SPECIFICATIONS/DIMENSIONS/CONNECTIONS

Model F		30	75	150
For Boiler Size	HP	1 - 30	31 - 75	80 - 150
Max. Boiler Pressure	PSI	150	150	150
Capacity	GALLONS	22	40.8	70.5
	LITERS	83	154	267
Weight	LBS	200	295	450
	KGS	91	134	204
<b>DIMENSIONS</b>				
(A) Height	IN	34	44	50
	MM	864	1118	1270
(B) Diameter	IN	18	20	24
	MM	457	508	610
(C) Tank Height	IN	20	30	36
	MM	508	762	914
(D) Vent	IN	3	4	4
	MM	76	102	102
(E) Drain	IN	1.5	1.5	1.5
	MM	38	38	38
(F) Water Supply	IN	.5	.75	.75
	MM	13	19	19
(G) Outlet	IN	3	3	3
	MM	76	76	76
(H) Inlet	IN	1.25	2	2
	MM	32	51	51
(I) Thermometer	IN	.50	.50	.50
	MM	13	13	13
(J) Handhole	IN	3 x 4	3 x 4	3 x 4
	MM	76 x 102	76 x 102	76 x 102
(K) Inlet Height	IN	26	31	34
	MM	660	787	864

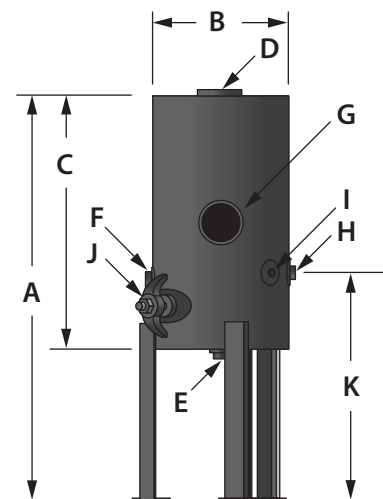

The heat transfer innovators.



Fulton Boiler Works, Inc.  
3981 Port Street  
Pulaski, NY 13142

Call: (315) 298-5121

Fax: (315) 298-6390



[www.fulton.com](http://www.fulton.com)

ICS-FBA\_BROCHURE\_220919