



# ENDURA XE™

Condensing Firetube  
Hydronic Boilers

399,000 – 750,000 BTU/HR



- ▶ Up to 15:1 Turndown
- ▶ Flame-by-Wire™ Combustion
- ▶ Real-Time O<sub>2</sub> Compensation™



Low NOx  
CERTIFIED



Hydrogen  
READY

*Up to 20% Blend*



# HEAVY-HITTER FOR ENERGY SAVINGS

Hundreds of thousands of installations around the world rely on Fulton's legendary rugged and reliable boilers. Like all Fulton products, the ENDURA XE is built to last and delivers leading-edge efficiencies and utility savings.

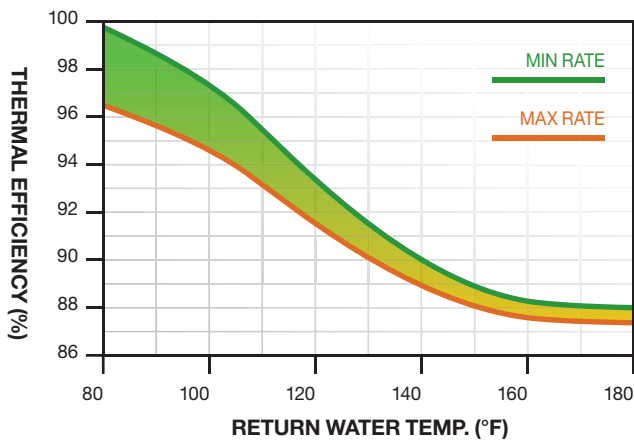

## Reduce Fuel Costs & Emissions

The ultra-high efficiency heat exchanger and fuel-saving burner reduce carbon emissions by 15% and NOx emissions by 80% compared to conventional boilers.

## Simplify Your Installation

Fully electronic combustion controls use Flame-by-Wire™ technology. This installer friendly system is simpler to learn and operate, significantly reducing commissioning time and complexity.

## Trusted Long-Life Durability

Firetube architecture is recognized for superior dependability and ease of installation. The ENDURA XE envelops tubes within a large volume of water, eliminating costly buffer tanks and primary-secondary piping.

## LOW MAINTENANCE RELIABLE BURNER

Fulton combines environmentally friendly low NOx emissions with the rugged durability of industrial-grade equipment. Burner maintenance has never been simpler.

- ▶ **Simpler Maintenance & Lower Cost of Ownership**
- ▶ **Even Tube Heat Loading for a Longer Lasting Heat Exchanger**
- ▶ **Exceptional Durability with Low NOx Emissions**

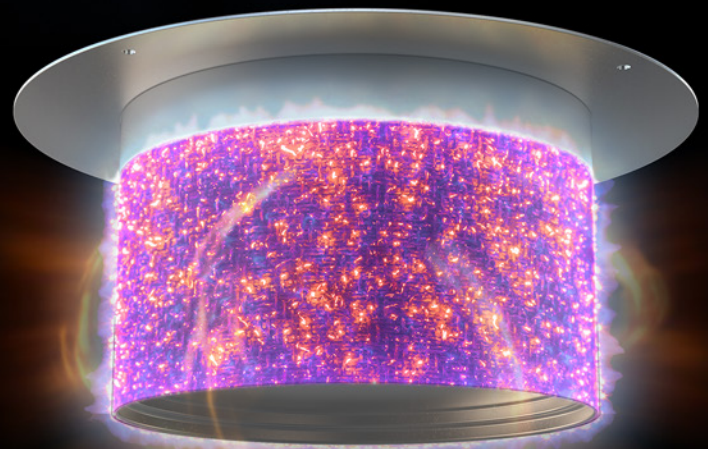

# FIRETUBE TECHNOLOGY

The ENDURA XE™ is engineered and built to the same rugged reliability standards as Fulton's heavy-duty industrial boilers. Superior construction materials and water management make the ENDURA XE last longer, even in the most demanding applications.

- ▶ **Protects Against Scale & Corrosion**
- ▶ **Built-in Buffer Reduces Cycling**
- ▶ **Lower Pump Head Requirements**



- ▶ **Supercharged Heating**

ENDURA XE packs more performance into a smaller package, keeping your building efficiently and reliably heated while saving valuable space in the mechanical room.

- ▶ **Stainless Heat Exchanger**

Type 439 stainless steel features 68% greater strength than 316L and is immune to chloride stress corrosion cracking, a catastrophic mode of failure seen with boilers using 304 and 316L.

- ▶ **Long-Lasting Durability**

Innovative water baffle technology prevents scale from forming, ensuring a long-lasting and efficient heat exchanger. This maximizes heating comfort and lowers lifetime fuel costs.



# PURE™ CONTROL

## Complexity Simplified

Fulton's powerful yet intuitive PURE Control™ provides rapid access to operating details and configuration. It efficiently sequences up to 10 boilers and eliminates the need for a master boiler or standalone panel. When a boiler is powered off, the plant seamlessly transitions to the next available stage for reliable heating.

- ▶ Outdoor Reset with Setback Mode
- ▶ Motorized Isolation Valve Control
- ▶ Variable Speed Pump Control
- ▶ Saves Energy by Reducing Cycling
- ▶ ModBus / BACnet Configurable

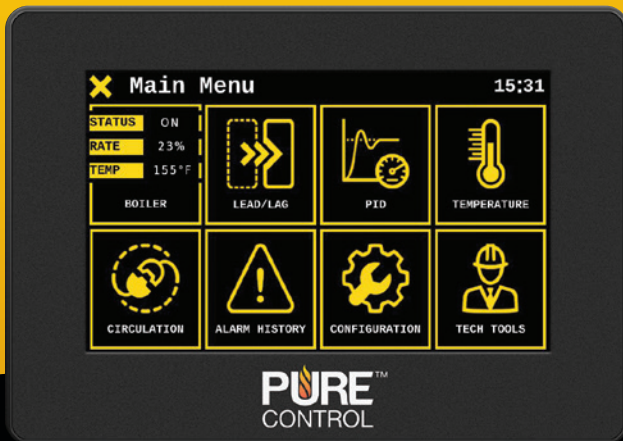

# FLAME BY WIRE™

## Combustion Technology

Inspired by advances in automotive and aviation, Flame-by-Wire™ technology replaces the use of conventional pneumatic ("neg-reg") and mechanical linkage systems with a modern system of independent air and gas valves. Real-time O2 Compensation™ continuously tunes the burner air-fuel ratio, automatically optimizing for seasonality.

- ▶ Simplifies Start-Up & Maintenance
- ▶ Maximizes Condensing Operation
- ▶ Reduces Fuel Bills & Emissions

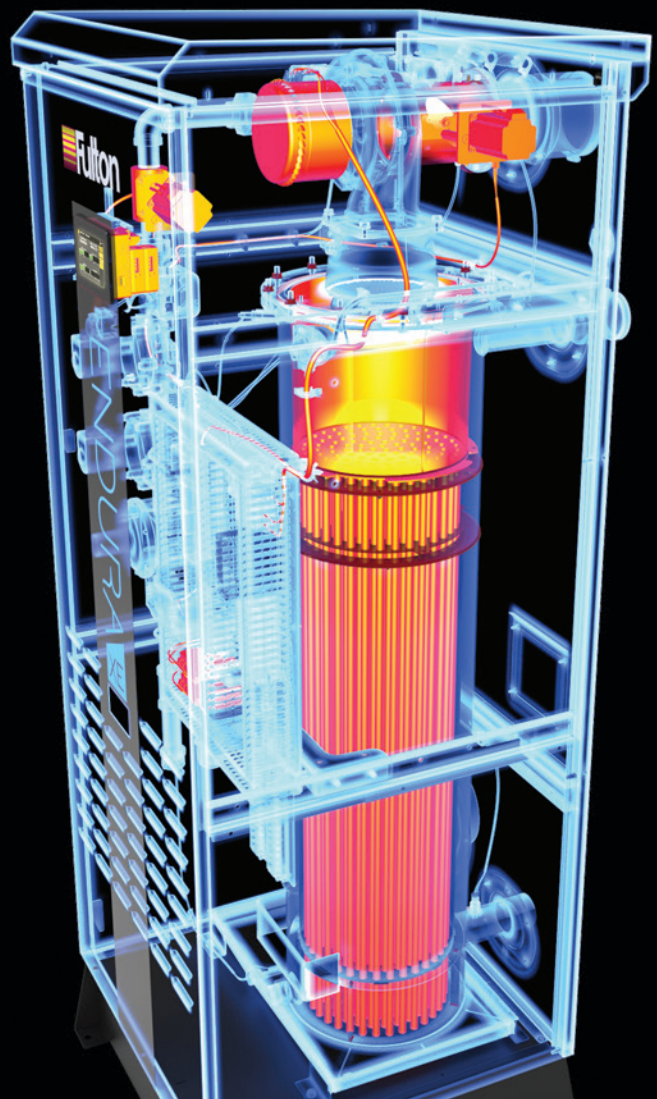

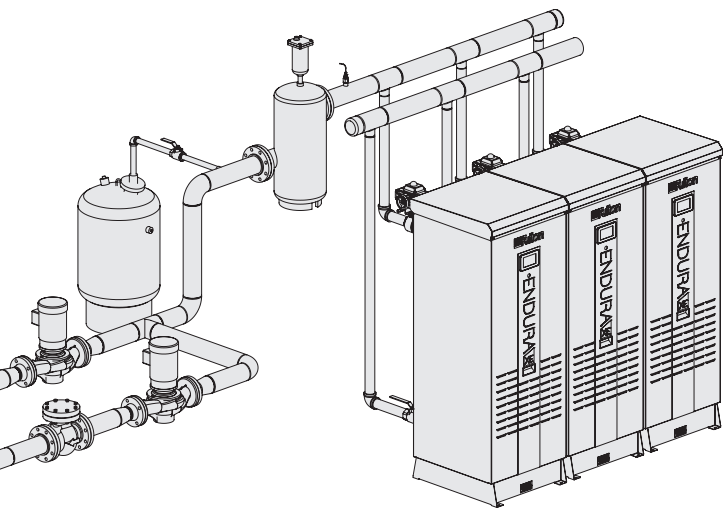

## VARIABLE PRIMARY FLOW DESIGN

Variable primary flow is a simplified piping method which enhances temperature comfort, reduces installation complexity, eliminates dedicated boiler pumps, and maximizes fuel savings by returning the lowest temperature water directly to the boiler inlet without the inefficient blending of a primary-secondary manifold.

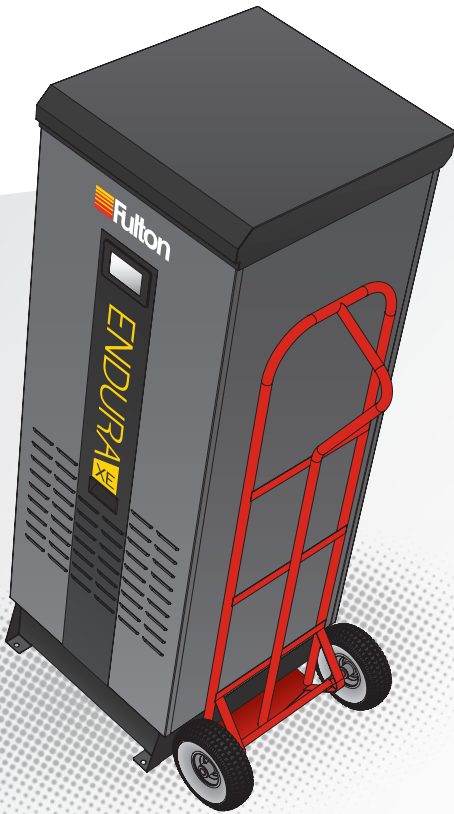

## Compact Design

The compact footprint and zero side clearance make the ENDURA XE an excellent choice for both retrofit and new construction, freeing up valuable mechanical room space.

## Flexible Venting Arrangements

ENDURA XE supports 16 different combinations of venting including sidewall or rooftop, room air or sealed combustion, plastic or stainless flue materials, and manifolded common venting.

ROOFTOP

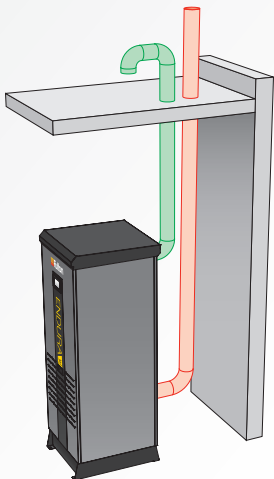

SIDEWALL

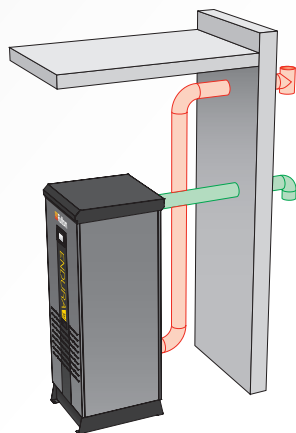

MIXED

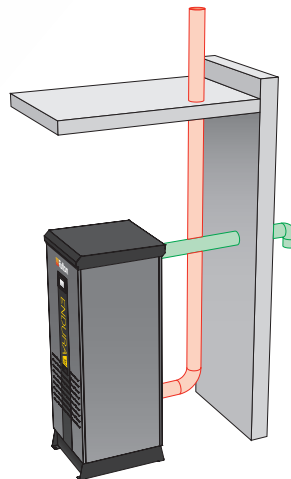

COMMON

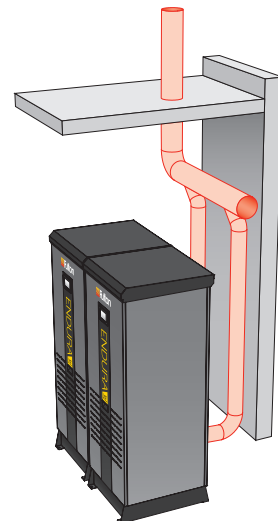

# SPECIFICATIONS & DIMENSIONS

	MODEL	EXE-399	EXE-500	EXE-650	EXE-750
<b>SPECIFICATIONS</b>					
Input Capacity	MBH	399	500	650	750
Water Content	GAL	17.9	17.9	17.9	17.9
Pressure Drop at 20°F ΔT	PSI	0.6	0.9	1.4	1.9
Operating Weight	LBS	674	674	674	674
AHRI Thermal Efficiency	%	98.0	97.3	96.3	96.0
<b>DIMENSIONS</b>					
(A) Height	IN	73.7	73.7	73.7	73.7
(B) Width	IN	26.3	26.3	26.3	26.3
(C) Depth	IN	28.9	28.9	28.9	28.9
<b>CLEARANCES</b>					
(D) Sides	IN	0	0	0	0
(E) Front	IN	24	24	24	24
(F) Top	IN	16	16	16	16
(G) Rear	IN	12	12	12	12

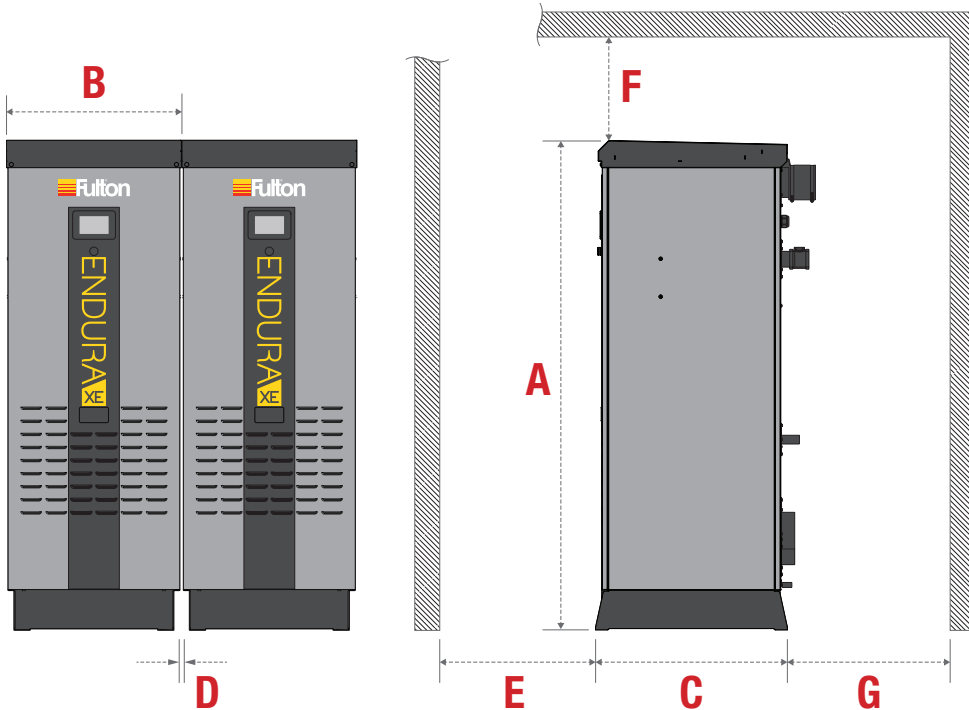

*NOTE: Specifications and dimensions are approximate and for reference only. Fulton practices continuous product improvement and reserves the right to change specifications and/or dimensions without notice.*



Call: (315) 298-5121

972 Centerville Road  
Pulaski, NY 13142



[fulton.com/enduraxe](http://fulton.com/enduraxe)



ENDURA-XE\_BROCHURE\_230727