



- ▶ **Lowest Cost of Ownership**
- ▶ **Best-in-Class Efficiency**
- ▶ **Versatile Burner Choices**

**STEAM MODELS:**

1000 - 30,000 lbs/h Output F&A 212°F  
ASME Section I & IV Designs to 800psi

**HOT WATER MODELS:**

1MM - 32MM Btu/hr  
ASME Section I & IV Designs

# FBX

**Flexible Watertube Boiler  
(Steam or Hot Water)**

**FACTORY PACKAGED  
OR FIELD ERECT  
30 – 900 BHP**

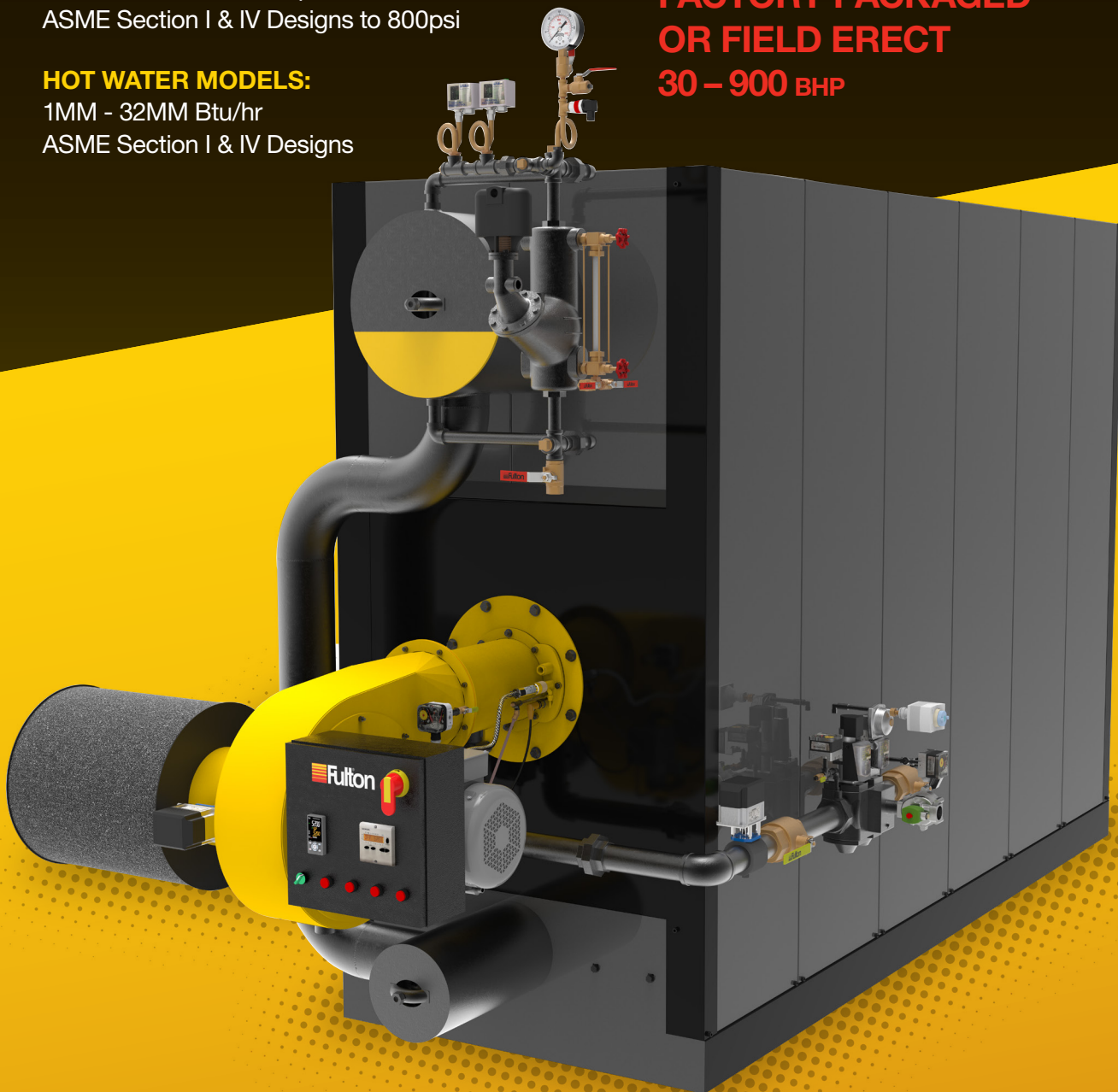

# SPECIFICATIONS & DIMENSIONS

## HIGH PRESSURE STEAM

## DIMENSIONS IN INCHES

MODEL*	INPUT (BTU/HR)	OUTPUT (BTU/HR)	OUTPUT (LBS/HR)	BHP	SHIPPING WEIGHT (LBS)	OPERATING WEIGHT (LBS)	BASE LENGTH (A)	BASE WIDTH (B)	HEIGHT (C)	TUBE PULL LENGTH (D)	STEAM OUTLET (E)	FLUE (F)
FB-0100-X-HP	1,250,000	1,013,000	1,000	30.5	4,170	4,640	51.25	35.5	76.6	18	1.5	8
FB-0150-X-HP	1,750,000	1,418,000	1,400	42.5	4,665	5,235	63.25	35.5	79.6	18	2	8
FB-0200-X-HP	2,200,000	1,782,000	1,760	53	5,530	6,210	63.25	39.5	83.6	22	2.5	10
FB-0250-X-HP	2,750,000	2,228,000	2,200	66.5	6,200	7,000	72.25	39.5	83.6	22	2.5	10
FB-0300-X-HP	3,000,000	2,430,000	2,400	72.5	6,700	7,560	72.25	43.5	88.6	26	3	12
FB-0350-X-HP	3,750,000	3,038,000	3,000	91	7,090	8,020	78.25	43.5	88.6	26	3	12
FB-0400-X-HP	4,300,000	3,463,000	3,440	104	7,700	8,735	87.25	43.5	88.6	26	3	14
FB-0500-X-HP	5,400,000	4,374,000	4,320	130.5	9,300	10,710	99.25	45.5	92.8	28	3	14
FB-0600-X-HP	6,250,000	5,063,000	5,000	151	10,200	11,760	111.25	45.5	92.8	28	4	16
FB-0700-X-HP	7,235,000	5,860,000	5,787	175	11,280	13,040	120.5	47.5	95.8	30	4	18
FB-0800-X-HP	8,270,000	6,699,000	6,615	200	12,785	14,645	120.6	51.5	102.8	34	4	18
FB-0900-X-HP	9,300,000	7,533,000	7,439	225	13,600	15,655	129.6	51.5	102.8	34	4	20
FB-1000-X-HP	10,330,000	8,367,000	8,262	250	14,850	17,095	141.6	51.5	102.8	34	6	20
FB-1200-X-HP	12,400,000	10,044,000	9,918	300	17,250	19,905	159.6	55.5	106.8	38	6	22
FB-1400-X-HP	14,470,000	11,720,000	11,574	350	18,590	21,480	174.9	55.5	106.8	38	6	24
FB-1600-X-HP	16,530,000	13,390,000	13,220	400	20,720	23,940	186.9	59.5	106.8	42	6	24
FB-1800-X-HP	18,600,000	15,066,000	14,757	450	23,500	27,545	186.7	65.5	115.3	48	6	26
FB-2000-X-HP	20,670,000	16,743,000	16,533	500	26,100	30,555	195.9	71.5	115.3	54	8	26
FB-2500-X-HP	25,000,000	20,250,000	19,997	605	31,800	38,300	204	84	136.8	70	8	28
FB-3000-X-HP	34,000,000	27,540,000	27,194	823	49,050	58,790	237-7/8	102	158.4	76	8	30
FB-3500-X-HP	38,000,000	30,780,000	30,395	920	55,000	66,270	266	102	167.4	76	8	32

TOP VIEW

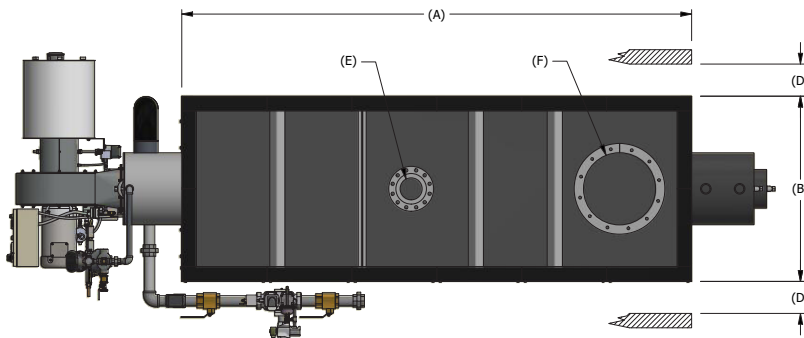

SIDE VIEW

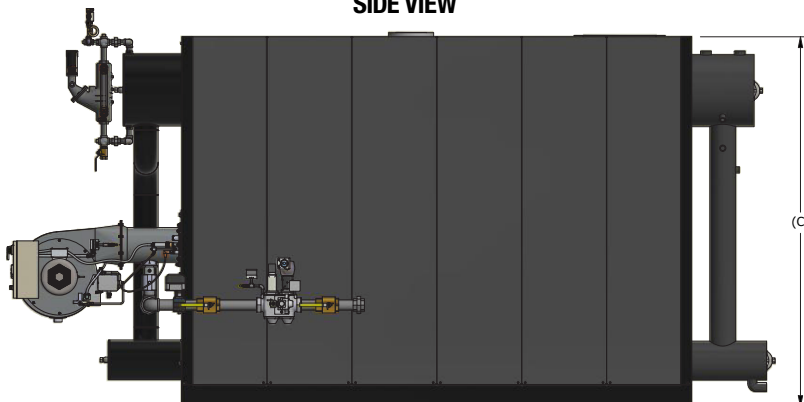

**NOTE:** Specifications and dimensions are approximate and for reference only. Fulton practices continuous product improvement and reserves the right to change specifications and/or dimensions without notice.

# SPECIFICATIONS & DIMENSIONS

## LOW PRESSURE STEAM

## DIMENSIONS IN INCHES

MODEL*	INPUT (BTU/HR)	OUTPUT (BTU/HR)	OUTPUT (LBS/HR)	BHP	SHIPPING WEIGHT (LBS)	OPERATING WEIGHT (LBS)	BASE LENGTH (A)	BASE WIDTH (B)	HEIGHT (C)	TUBE PULL LENGTH (D)	STEAM OUTLET (E)	FLUE (F)
FB-0100-X-LP	1,250,000	1,037,000	1,068	31	3,910	4,380	51.25	35.5	76.6	18	2	8
FB-0150-X-LP	1,750,000	1,453,000	1,497	43	4,370	4,940	63.25	35.5	79.6	18	2.5	8
FB-0200-X-LP	2,200,000	1,826,000	1,880	54	5,250	5,930	63.25	39.5	83.6	22	3	10
FB-0250-X-LP	2,750,000	2,280,000	2,350	68	5,810	6,610	72.25	39.5	83.6	22	3	10
FB-0300-X-LP	3,000,000	2,490,000	2,565	74	6,300	7,160	72.25	43.5	88.6	26	3	12
FB-0350-X-LP	3,750,000	3,110,000	3,205	93	6,660	7,590	78.25	43.5	88.6	26	4	12
FB-0400-X-LP	4,300,000	3,570,000	3,675	106	7,235	8,270	87.25	43.5	88.6	26	4	14
FB-0500-X-LP	5,400,000	4,480,000	4,616	134	8,780	10,190	99.25	45.5	92.8	28	4	14
FB-0600-X-LP	6,250,000	5,187,000	5,345	155	9,660	11,220	111.25	45.5	92.8	28	6	16
FB-0700-X-LP	7,235,000	6,005,000	6,185	179	10,700	12,460	120.5	47.5	95.8	30	6	18
FB-0800-X-LP	8,270,000	6,864,000	7,070	205	12,190	14,050	120.6	51.5	102.8	34	6	18
FB-0900-X-LP	9,300,000	7,719,000	7,950	230	13,000	15,055	129.6	51.5	102.8	34	6	20
FB-1000-X-LP	10,330,000	8,574,000	8,831	256	14,200	16,445	141.6	51.5	102.8	34	8	20
FB-1200-X-LP	12,400,000	10,292,000	10,600	307	16,500	19,155	159.6	55.5	106.8	38	8	22
FB-1400-X-LP	14,470,000	12,010,000	12,370	358	17,800	20,690	174.9	55.5	106.8	38	8	24
FB-1600-X-LP	16,530,000	13,720,000	14,131	410	19,900	23,120	186.9	59.5	106.8	42	8	24
FB-1800-X-LP	18,600,000	15,438,000	15,900	461	22,600	26,645	186.7	65.5	115.3	48	10	26
FB-2000-X-LP	20,670,000	17,156,000	17,670	512	25,100	29,555	195.9	71.5	115.3	54	10	26
FB-2500-X-LP	25,000,000	20,750,000	21,372	620	30,300	36,800	204	84	136.8	70	10	28
FB-3000-X-LP	34,000,000	28,220,000	29,065	843	47,100	57,830	237-7/8	102	158.8	76	12	30
FB-3500-X-LP	38,000,000	31,540,000	32,486	942	535,250	63,790	266	102	167.4	76	12	32

TOP VIEW

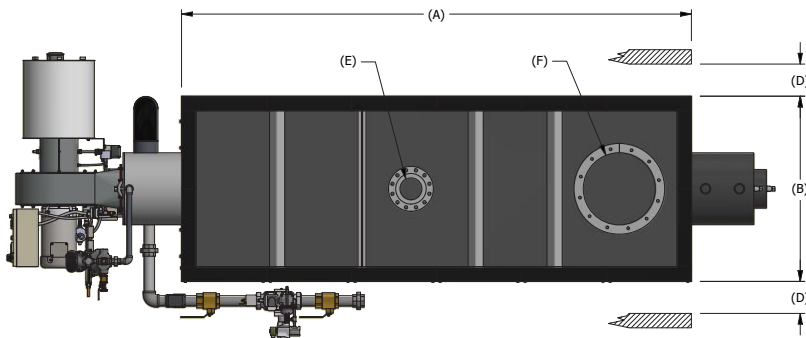

SIDE VIEW

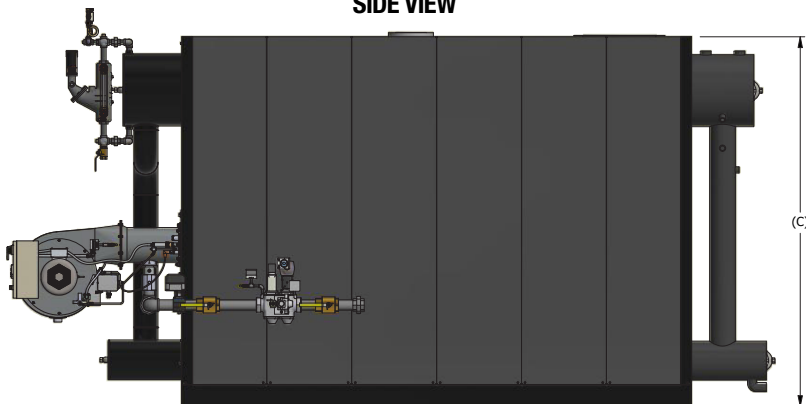

**NOTE:** Specifications and dimensions are approximate and for reference only. Fulton practices continuous product improvement and reserves the right to change specifications and/or dimensions without notice.

# SPECIFICATIONS & DIMENSIONS

HOT WATER				DIMENSIONS IN INCHES							
MODEL*	INPUT (BTU/HR)	OUTPUT (BTU/HR)	BHP	SHIPPING WEIGHT (LBS)	OPERATING WEIGHT (LBS)	BASE LENGTH (A)	BASE WIDTH (B)	HEIGHT (C)	TUBE PULL LENGTH (D)	WATER OUTLET/ INLET (E)	FLUE (F)
FB-0100-X-HW	1,250,000	1,062,000	31.5	3,290	3,790	51	35.5	71.5	18	2.5	8
FB-0150-X-HW	1,750,000	1,488,000	44.5	3,800	4,380	63	35.5	71.5	18	2.5	8
FB-0200-X-HW	2,200,000	1,870,000	56	4,400	5,035	63	39.5	76	22	3	10
FB-0250-X-HW	2,750,000	2,338,000	70	5,000	5,750	72	39.5	76	22	3	10
FB-0300-X-HW	3,000,000	2,550,000	76	5,600	6,410	72	43.5	80.5	26	4	12
FB-0350-X-HW	3,750,000	3,188,000	95.2	6,100	6,985	78	43.5	80.5	26	4	12
FB-0400-X-HW	4,300,000	3,655,000	109	6,800	7,800	87	43.5	80.5	26	4	14
FB-0500-X-HW	5,400,000	4,590,000	137	8,200	9,660	99.3	45.5	85	28	5	14
FB-0600-X-HW	6,250,000	5,313,000	159	9,000	10,625	111.3	45.5	85	28	5	16
FB-0700-X-HW	7,235,000	6,150,000	184	10,000	11,820	120.5	47.5	87	30	5	18
FB-0800-X-HW	8,270,000	7,030,000	210	11,400	13,650	120.5	51.5	95	34	6	18
FB-0900-X-HW	9,300,000	7,905,000	236	12,140	14,580	129.5	51.5	95	34	6	20
FB-1000-X-HW	10,330,000	8,780,000	262	13,200	15,870	141.5	51.5	95	34	6	20
FB-1200-X-HW	12,400,000	10,540,000	315	15,480	18,625	159.5	55.5	99	38	6	22
FB-1400-X-HW	14,470,000	12,300,000	367	16,600	20,100	174.8	55.5	99	38	8	24
FB-1600-X-HW	16,530,000	14,050,000	420	18,800	22,680	186.8	59.5	101	42	8	24
FB-1800-X-HW	18,600,000	15,810,000	472	20,960	25,210	186.8	65.5	106.5	48	8	26
FB-2000-X-HW	20,670,000	17,570,000	525	22,700	27,290	195.8	71.5	106.5	54	8	26
FB-2500-X-HW	25,000,000	21,250,000	635	28500	35,000	204.4	84	129.4	60	10	28
FB-3000-X-HW	34,000,000	28,900,000	863	43160	53,880	237.5	102	147.5	76	10	30
FB-3500-X-HW	38,000,000	32,300,000	965	49000	61,340	265.5	102	157.5	76	12	32

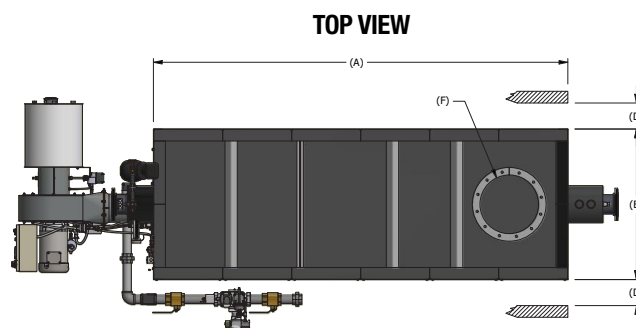
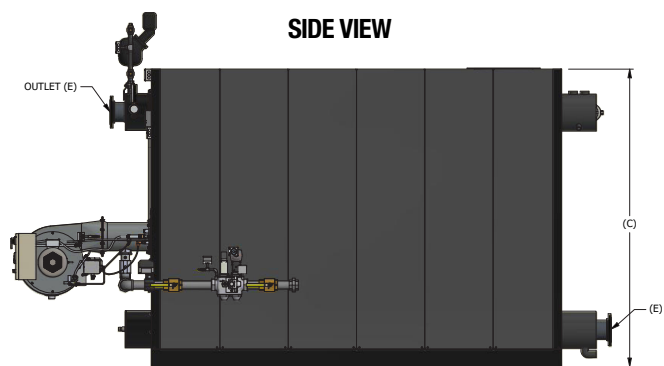

**NOTE:** Specifications and dimensions are approximate and for reference only. Fulton practices continuous product improvement and reserves the right to change specifications and/or dimensions without notice.



Call: (315) 298-5121

[www.fulton.com](http://www.fulton.com)

972 Centerville Road  
Pulaski, NY 13142



FBX-BROCHURE-221026